



# Waste Management Winter RallySprint (WMWR)

## 2018

# Supplemental Rules

15 Dec 2018



Welcome to the Waste Management Winter RallySprint.

This is our second year as a SCCA RallySprint.

The goals for this event are varied.

1. To provide a path to competition in Regional Stage Rally.
2. Training of personnel organizing and running stage rally events.

Many of the people involved in organizing are well seasoned with many years of experience creating stage rallies such as the Susquehannock Trail Performance Rally (STPR). Others are new to their area of responsibility.

We expect both experienced competitors in cars with “Rally Patina” and new competitors in cars that may be new to them or new to rally.

Please have patience, we are all learning.

Waste Management, Inc., is most gracious as both sponsor and host of this event. They have allowed creation of roads and spectator areas on their property as well as putting up with the inconvenience of hosting this event. We thank them and the management of Danzer Forestland LLC. for their permissions and efforts.

The Wellsboro Chamber of Commerce is the other sponsor of the Waste Management Winter RallySprint. This year we are also part of the Wellsboro Winter Celebration. Our parc expose on The Green in the center of town will allow you to join the festivities and for the festival goers to see your cars, meet the teams, and learn about the sport.

Please visit <http://www.wellsboropa.com/> for more information on the beautiful, historic, and friendly area.

Constructive comments and criticism will be appreciated to improve the quality of future events.

Welcome  
David Avery  
Chairman

## I. Event Description:

- A. Name: Waste Management Winter RallySprint
- B. Rally Headquarters: Tioga County Fairgrounds
  - 1. 2258 Charleston Rd, Wellsboro, PA 16901
  - 2. [Google Maps Link](#)
  - 3. 41° 46' 09.8" N, 77° 12' 19.1" W
- C. Event Date: Saturday, February 17, 2018
- D. Sanction: This event is sanctioned by the Sports Car Club of America (SCCA), and hosted by the Finger Lakes Region, SCCA.
- E. Insurance: This event is insured through the Sports Car Club of America (SCCA).
- F. This RallySprint is not part of any series or championship.
- G. This RallySprint is about 56 miles in length. As the service area will be on-site there will only be very short transits between stages. The RallySprint consists of the complete Waste Management stages run thrice in one direction and twice in the other direction.
- H. Purpose: The Waste Management Winter RallySprint is designed to provide affordable seat time to the aspiring rally community. The RallySprint will also give new volunteer workers a chance to learn a position and experienced workers will have an opportunity to try new positions.
- I. Supplemental Rules: These Supplemental rules may be updated prior to the event. The revision number and date will be your verification that you are looking at the most recent edition. Revisions will be in italics.

## II. Entry:

- A. Entry will only be accepted on-line through <http://www.dlbracing.com/>. Entry will be considered complete when all required entry forms and materials are submitted and payment in full is received.

## III. Entry Schedule and fees:

12:00 AM	January 1, 2018	Early registration opens	\$300/team SCCA members \$320/team non-members
11:59 PM	February 1, 2018	Early registration closes	
12:00 AM	February 2, 2018	Late registration opens	\$340/team SCCA members \$360/team non-members
10 AM	February 17, 2018	Late registration closes	All paperwork FINISHED
		Weekend Membership – required if not an SCCA member	\$10 per person
		Additional Service Crew Kits	\$50 per kit

### A. Payment:

- 1. Credit Card Entry fees will be collected electronically through DLBracing.com up to Midnight February 14, 2018.
- 2. Other options for payment include check or money order mailed to the Registrar until February 7, 2018. After February 7, 2018, payment may be made by certified check or money order. On-site entries must be paid in cash or credit card.

3. Checks that do not clear upon first deposit will incur a \$50 fee to cover bank and processing costs. The “returned” check must be replaced by February 7th, with a certified check or money order, or the entry position will be forfeited. The entrant will remain liable for the \$50 fee.
4. Refunds: Withdrawals before February 10, 2018 will have no penalty. Withdrawals from February 10 to February 17 will receive a 75% refund. Once a team starts the event (incl. Recce), there will be no refund.

IV. **SCCA Membership: Either driver or co-driver, or both may be current SCCA members to receive the member pricing. An SCCA membership affords teams the best entry fee.**

- A. Non-SCCA entrants: Non-members (anyone that will be in a competition vehicle) must purchase a weekend membership for \$10 per person. This is in addition to the team entry fee.
- B. License: Per SCCA RallySprint rules

V. **Number of Entrants:**

- A. The event will be limited to 30 teams. A team consists of a driver and a co-driver. A team is not officially entered until all required entry forms and materials are submitted and payment in full is received. A “wait list” will be maintained in the case of withdrawals.

VI. **Required Documentation:**

- A. For an entry to be considered complete, the following must be submitted:
  1. Fees: Entry, weekend membership – submitted on-line
  2. Required driver, co-driver, vehicles and crew information
  3. Drivers and co-drivers competition license – or evidence of meeting SCCA requirements
  4. Drivers and co-drivers driving license
  5. Vehicle registration
  6. Proof of vehicle insurance (declarations page)
  7. A letter of permission to use the rally vehicle if not registered either to the driver, the co-driver, or the entrant.
  8. Service vehicle registration
  9. Proof of service vehicle insurance
  10. SCCA Membership Card or weekend membership
  11. All documents must be valid for the duration of the rally.
  12. Waivers: All team members and crew must sign the required waivers upon entering the property.
- B. It is **STRONGLY** suggested that all documentation be submitted in electronic form to the Competitor Registrar at least one week before the event. This will speed up onsite registration and allow time to resolve any issues. [registrar@stpr.org](mailto:registrar@stpr.org)

## VIII. Organizing Committee:

Chairman	David Avery	<a href="mailto:dwa@dwavery.com">dwa@dwavery.com</a> 585.737.6541
Rallymaster	Alan Smith	<a href="mailto:rallymaster@stpr.org">rallymaster@stpr.org</a>
Competitor Registrar <i>Thank you for calling/faxing only between 8 am and 10 pm Eastern Standard Time</i>	SueAnne Carson 2017 Yale Street Wellsboro, PA 16901	<a href="mailto:registrar@stpr.org">registrar@stpr.org</a> 570.772.5529 Cell
Chief of Controls	James Monks	<a href="mailto:controls@stpr.org">controls@stpr.org</a>
Volunteer Registrar	David Avery	<a href="mailto:dwa@dwavery.com">dwa@dwavery.com</a> 585.737.6541
Co-Assistant Radio Chiefs	Dave Moore-administration/ Phil Hemenway-radio and network maintenance	<a href="mailto:comm@stpr.org">comm@stpr.org</a>
Medical Services Coordinator	Jamie Sue Parker	<a href="mailto:medical@stpr.org">medical@stpr.org</a>
Scoring Chief	TBA	
Scrutineering	Don Taylor	<a href="mailto:scrutineer@stpr.org">scrutineer@stpr.org</a>
Service Coordinator	Kevin Weiskopff	<a href="mailto:Kevinhd1@yahoo.com">Kevinhd1@yahoo.com</a>
Sweep Coordinator	Dale Howey	<a href="mailto:sweep@stpr.org">sweep@stpr.org</a>
Safety Sweep Coordinator	John Werner	<a href="mailto:safetysweep@stpr.org">safetysweep@stpr.org</a>
Spectator Coordinator	Roy Bucher	<a href="mailto:spectators@stpr.org">spectators@stpr.org</a>
Finger Lakes Region SCCA	Charlie Tanck	<a href="mailto:re@flr-scca.org">re@flr-scca.org</a>
Wellsboro Chamber of Commerce	Julie VanNess	<a href="mailto:JulieV@wellsboropa.com">JulieV@wellsboropa.com</a>
Steward of the Meet	Steve Hyatt	<a href="mailto:stephen@atspeed.org">stephen@atspeed.org</a>

X. Tentative Schedule

Friday, February 16		
3 – 4 PM	RECCE for Stages 1,2,3	N41 39.109, W77 15.780
4 – 5 PM	Recce for Stage 5, 6	
5 – 8 PM	Scrutineering for all cars. No appointment needed. Team crew at Scrutineering must be registered! Tech will CLOSE at 8PM, if there is not enough time to properly check your vehicle you will be asked to return Sat AM.	TBA
5 – 8 PM	Volunteer Registration	<a href="#">Fairgrounds</a>
5 – 8 PM	Competitor Registration and Service Crew Registration	<a href="#">Fairgrounds</a>
6 – 8 PM	RallySprint Safety Steward Training	<a href="#">Fairgrounds</a>
Saturday, February 17		
8 – 10:00 AM	Competitor Registration and Service Crew Registration NOTE: If you need special consideration, please contact the Competitor Registrar Prior to event day.	TBA
7 – 9 a.m.	Volunteer Registration NOTE: If you need special consideration, please contact the Volunteer Registrar prior to event day.	<a href="#">Fairgrounds</a>
7 – 9 a.m.	Scrutineering for all cars. No appointment needed. Team crew at Scrutineering must be registered!	
10:30 a.m.	Start List posted at the notice board at Registration	<a href="#">Fairgrounds</a>
10:00 a.m.	Novice seminar for new rallyists	<a href="#">Fairgrounds</a>
11:00 a.m.	Parc Exposé at The Green (downtown Wellsboro)	Follow Route Book
11:58 a.m.	Section A begins	<a href="#">The Green</a>
3:01 p.m.	1st car arrives at Service; begin 60-minute service	
4:01 p.m.	Section B begins	
5:43 p.m.	First car finishes the Rally	
6:14 p.m.	Last car finishes the Rally	
ASAP after rally ends	Posting of Provisional Scores NOTE: deadline for filing scoring inquiries and claims is 30 minutes after posting. Awards Buffet Dinner	<a href="#">Fairgrounds</a>

XI. Timing: Stage timing will be in minutes and hundredths

XII. Competition Classes. Per the current RallySprint Rules:

- A. **RallySprint Two-Wheel Drive Under 2.5 Liters (R2U)** – for front- or rear-wheel drive vehicles with adjusted engine capacity under 2.5 liters.
- B. **RallySprint Two-Wheel Drive Over 2.5 Liters (R2O)** – for front- or rear-wheel drive vehicles with adjusted engine capacity of 2.5 liters or greater.

- C. **RallySprint Four-Wheel Drive Under 2.5 Liters (R4U)** – for all- or four-wheel drive vehicles with adjusted engine capacity under 2.5 liters.
- D. **RallySprint Four-Wheel Drive Over 2.5 Liters (R4O)** -- for all- or four-wheel drive vehicles with adjusted engine capacity of 2.5 liters or greater.

### XIII. Log Books:

- A. All cars entering this event have a log book recognized through American Rally Association, Rally America, or NASA RallySport. If log booked through another organization, you must contact the Chief Scrutineer at least one week prior to the rally for approval.
- B. Issuing of Log Book: Due to the compressed schedule for this event, there will be no inspection sessions to issue log books.

### XIV. Required Vehicle Safety Equipment: The following are the minimum safety requirements for the vehicle. It is expected that safety equipment is installed in a manner consistent with manufacturers' intent.

- A. Cages: In the instance that a vehicle is older, but still log booked, all cages, regardless of log book must have diagonal bars and 2 door bars. See diagrams below. For questions regarding cages, contact the scrutineer.

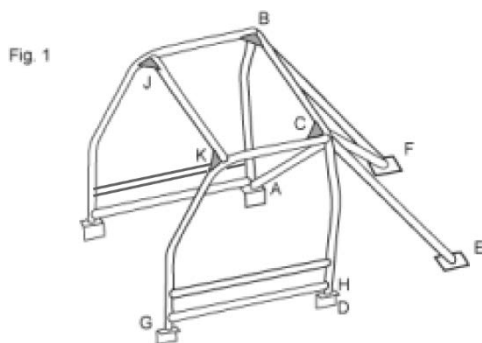

#### LEGEND

- |                           |                    |
|---------------------------|--------------------|
| A, B, C & D Main Hoop     | G, H Side Sill Bar |
| B, F & C, E Rear Bars     | J, K Front Gussets |
| C, A Diagonal Lateral Bar | B, C Rear Gussets  |
| C, F Diagonal Rear Bar    |                    |

- B. Padding: Any portion of the roll cage which could come into contact with the driver or co-driver's helmet during competition, including all bars in the plane of the roof and forward of the main hoop, shall be covered with energy absorbing material compliant with either the SFI 45.1 specification or FIA Standard 8857-2001 Type A.
- C. Seats: Driver and co-driver seats shall be firmly mounted to the structure of the vehicle and be installed per the manufacturer's recommendations. Seats must be intended by their manufacturer to be for competition use.
- D. Harnesses: All vehicles shall be equipped with a five-, six- or seven-point occupant restraint (harness) system meeting the specifications below for both the driver and co-driver. All harness systems shall be capable of releasing with only one latch. These harnesses shall be worn at all times while driving or co-driving. B. Harnesses shall meet the requirements of FIA Standard 8853/98 and/or be SFI 16.1 or SFI 16.5 licensed and shall be labeled accordingly.
- E. Emergency Triangle: each vehicle will carry a minimum of 3 safety triangles.
- F. Fire extinguishers: One fire extinguisher with a minimum UL rating of 10 BC or two each with a minimum rating of 5 BC must be installed inside the passenger compartment. One fire extinguisher must be located within easy reach of the driver or co-driver when seated. Extinguisher brackets must be metal.
- G. Scrutineering: Vehicle and personal safety equipment must be inspected and approved before any vehicle or person may begin competition. A "Tech Form" sample is included in the Appendix to assist teams be properly prepared.
- H. Tires cannot be studded or have any metal insertions.

**XV. Required Personal Safety Equipment: The following items are required for all drivers and co-drivers:**

- A. Helmets: All drivers and co-drivers competing must wear helmets that meet one of the following standards:
  - 1. Snell SA2010 or SA2015
  - 2. Snell SAH2010
  - 3. SFI Spec 31.1/2005 or newer
  - 4. FIA 8860-2004
  - 5. FIA 8860-2010
  - 6. British Standard 6658-85 Type A/FR, including all amendments will be valid for 10 years from the date of manufacture. If no manufacturing date sticker exists, the helmet will be considered expired.
- B. Head and Neck Restraint Device: Head and neck restraint systems are required for all competitors. These systems shall be mounted per the manufacturer's recommendations. The head and neck restraint system must meet at least one of the following:
  - 1. Certified to FIA 8858-2002.
  - 2. Certified to FIA 8858-2010.
  - 3. SFI 38.1 licensed. SFI 38.1 licensing requires a SFI 38.1 conformance label that is less than five years old.
- C. Driving suit: All drivers and co-drivers competing must wear driving suits that conform to one of the following standards:
  - 1. FIA 8856-2000
  - 2. FIA 1986 or
  - 3. SFI 3-2A/5.



4. SFI 3-2A/1 driving suits are also permitted if worn with approved fire resistant underwear.

- XVI. Stage and Transit Notes: There will be a route book with tulip diagrams. No stage notes provided or allowed.
- XVII. Recce: We are offering RECCE of the stages on Friday February 16 afternoon. See schedule for times.
- A. There is no additional fee for RECCE.
  - B. Competitors may use their competition car for RECCE.
  - C. Teams should meet at the ATC of stage 1, 2 and 3 at the corner of Antrim Road and Hunters Road. GPS Coordinates are [N41 39.109, W77 15.780](#)
- XVIII. Car numbers:
- A. Each team may choose their car number. In the case of duplicate numbers, an SCCA membership will provide priority in choice. If neither entrant is an SCCA member, the first entrant registered will have priority.
  - B. All vehicles must carry competition numbers in the required locations. These may be nationally or internationally assigned numbers or off the shelf numbers provided by the competitor.
  - C. Handmade (tape or similar) numbers are not acceptable.
  - D. Service Vehicle Identification: All service vehicles must carry the car number of each vehicle they are servicing.
  - E. Car numbers are not supplied by the event and are the responsibility of the entrants.
  - F. Numbers: Car numbers should be 8" tall and 1.25" brush width minimum.
  - G. Numbers displayed in a color contrasting to its background.
  - H. Event stickers will be required (and supplied)
- XIX. Scrutineering
- A. Scrutineering location will be at the Tioga County Fairgrounds.
  - B. Scrutineering will be done on a first come first serve basis. The pre-printed Scrutineering form must accompany the vehicle to Scrutineering.
  - C. Team Crew at Scrutineering must be registered!
  - D. Scrutineering on Friday night will close PER THE SCHEDULE. If you arrive too late to be inspected properly in the available time, you will be told to return on Saturday.
  - E. If you need special consideration for after hours, please contact the Scrutineering Chief directly for help prior to the event.
- XX. Score Adjustments
- A. The Event Chairman or stewards have the right to correct any obvious and substantiated timing errors.
  - B. Speeding during Recce and Transit Stages will incur penalties:
    1. ½ minute for every mile above the posted limit up to 2.5 minutes in penalties.
    2. 1 minute for every mile above 10 MPH over the posted limit up to 7.5 minutes in penalties.
    3. 2 minutes for every mile above 15 MPH over the posted limit.
  - C. Receiving a traffic citation during transit stages may disqualify the team.

- D. Teams purposefully destroying course controls (Hay bales as chicanes etc.) will be assessed a bogey time for that stage.

## XXI. Emergency Procedures on a Special Stage

### A. Warning Triangles

1. If a competition team stops for any reason on a special stage they must attempt to place the vehicle off the road so as not to impede the flow of traffic.
2. Triangles should be placed on the side of the road indicating the upcoming hazard to following competitors.
3. The first triangle must be placed at the vehicle immediately upon stopping.
4. The second triangle must be placed about 150' from the vehicle.
5. The third triangle must be placed about 300' from the vehicle.
6. Place triangles where they will be seen by oncoming vehicles. Crest, turns, and other obstacles should be considered when placing triangles. Opt for safety.
7. All triangles must be on the same side of the road as the stopped vehicle.
8. Competitors not displaying warning triangles are subject to penalties.
9. Competitors must remove all warning triangles before continuing on a special stage.
10. Any competitor coming upon a posted warning triangle should slow down to a speed that will allow the competitor to be prepared to stop for the incident.

### B. Display either the OK or the Red Cross.

1. If you need medical assistance display the Red Cross (Located at the back of the route book)
2. If you need immediate assistance (Such as fire) Display the red cross.
3. If you do not need immediate assistance display the OK sign (Located in the back of the route book).

### C. Approach to Disabled Vehicle

1. When a competition team approaches a disabled vehicle on a special stage, they must respond as follows:
  - a) if the OK sign is displayed, the competition team may proceed.
  - b) If the OK sign is not displayed, the competition team must stop.
  - c) If there are no injuries, the OK sign must be displayed so other competitors will not be delayed on the special stage. If there are injuries, the Red Cross sign must be displayed and the emergency procedures below should be followed

### D. Red Cross Displayed

1. If the Red Cross sign is displayed, the competition team must stop. If there are injuries, assistance should be rendered to the injured persons. Competitors should send the next competition vehicle to the next Radio Location or Control marked in the route book. If a radio is available, they should contact the radio net. The following vital information must be communicated:
  - d) The nature of the accident type and severity of the injuries and the number of injured persons.
  - e) Location of the accident, mileage if possible from the start of the special stage.
  - f) What to look for at the accident site: clearings, flashing lights, rocks, etc.
2. After sending help or contacting the radio net, steps should be taken at the accident site to prepare for the arrival of the EMT team. This should include making sure the roadway is clear for traffic, clearing brush and debris from the vehicle or injured persons, and if necessary marking the accident site for helicopter landing site. All other competition vehicles arriving must stay at the scene.

- E. Event Official Use of the Red Cross
  1. If an event official uses a Red Flag, this use signals a competitor to stop on a special stage, the competitor is to stop as safely as possible, place their vehicle to allow clear passage on the road, and wait for directions from event officials.
- F. Red Cross Sign Display or Red Flag Stops All Competition
  1. Once a Red Cross sign or a Red Flag has been displayed, all competition on the special stage is halted. Event officials will advise competitors how to proceed. Competition may resume on a special stage once the emergency situation has been resolved.
- G. Scoring of Halted Special Stage
  1. If a special stage is halted after one or more competitors has completed the special stage, the event officials may assign scores to all following vehicles based on the finishing time of the slowest representative vehicle finishing the special stage prior to the incident. No competitor who is responsible for the stoppage of the special stage can benefit from this action.
- H. Assistance on a Special Stage or Transit
  1. A competing vehicle must complete each stage and each transit under its own power except when assistance is unplanned.
  2. Assistance may include towing or pushing from any person or competitor other than a person working as a service member of the competitor's crew. Official permission or instruction may also allow assistance. A competing vehicle may not be towed or hauled at any time during the event by trailer or tow truck so that its wheels leave the road surface. Competitors receiving illegal assistance will be removed from competition at the point of infraction

## XXII. Service:

- A. General: The service area will be crowded. Please keep your area as compact as possible.
- B. Service kits will be issued to each Service Crew upon registration. Kits include a Running Schedule, Route Map, Supplemental Regulations (with Odometer Calibration Run), Service Route Instructions, Service Area locations, and contact information for Emergency Services.
- C. Service Site
  1. Selection of service spaces will be on a first come first serve basis during Registration except as described below.
  2. There is an additional fee of \$50 per additional service space at the Waste Management Site.
  3. Teams with oversize service rigs need to pre-register with the Competitor Registrar. We will try to accommodate the need for increased space.
  4. A footprint of your service vehicle is required due to the unknown space needs. Please send this information to the Competitor Registrar. She will relay that to the Service Manager.
- D. There is a limit of Two service vehicles per competing vehicle. Each service vehicle and its personnel must be registered. Proof of Insurance (declarations page) for all service vehicles is required at Registration. If the driver of the service vehicle is not the owner, a letter of permission to use the vehicle is also required.
- E. A service vehicle that is servicing more than one team counts as one of the two allowed service vehicles for each team it is servicing. For example: If car 72 and 472 share a service vehicle there are only three service vehicles allowed between the two teams. This will be monitored by the numbers issued for ID at Service Crew Registration.

- F. Each Service Vehicle must be identified by the number (or Numbers) of the car (or cars) that it is servicing. Numbers must be affixed to the upper center windshield so as not to obstruct the view of the driver of the vehicle.
- G. Tarps or spill cloths are required for all servicing operations. There is a \$50 penalty for failure to comply.
- H. There will be an official with radio communications at the Service Area. This person will be responsible for managing the area and helping crews find missing vehicles. Net Control frequencies are listed in the Route Book and Service Route Book for your convenience and monitoring. Service Crews and Rally Teams will NOT be permitted to contact Net Control directly with the exception of a medical emergency.
- I. Service Crews are required to notify the Service Area Coordinator when they leave a service area to retrieve a vehicle they are servicing for.
- J. There is space very close to the Service Area where crews may watch. Please make sure your wristband is on at all times as this is not a public spectating area.
- K. Trash: This is carry in – carry out. Do not leave garbage behind, including cigarette butts.
- L. Fueling:
  - 1. Teams should bring enough fuel to run the day. There is no fuel availability on site and there is not time to leave to get fuel.
  - 2. All fueling will take place in the assigned fuel depot area (consistent with stage rally rules).
  - 3. A team member must be standing by with fire extinguisher in hand during fueling. (Consistent with stage rally rules).
- M. Repairs: Jack stands must be placed under the vehicle when more than one wheel is in the air. Jack stands are to be used any time a person is to work under a jacked vehicle.

### XXIII. Refueling and Service Summary

<b>Waste Management Winter Rally Refueling &amp; Service Summary</b>	Transit miles	Stage miles	Fuel mileage
<b>Saturday, February 17</b>			
Stages 1 & 2 & 3	5.81	26.24	
Service			32.45
Stages 4 & 5	5.84	17.74	
Service			23.58
<b>Totals</b>	<b>11.65</b>	<b>44.38</b>	<b>56.03</b>

### XXIV. Maximum Permitted Lateness

- A. Maximum Permitted Lateness (MPL) shall not exceed 30 minutes for the entire event, or 15 minutes lateness per stage.
- B. MPL will be accumulated by exceeding the time allowance between two timing controls, the bogey (slow) time allowance for a special stage, or a combination of the two.

- C. The penalty for exceeding MPL is exclusion from the event, this is also known as being Time Barred.
- D. In no case may early arrival at controls be used as a means of reducing accumulated MPL.
- E. Service time may be reduced by lateness time to facilitate the next stages. This will not reduce your accumulated MPL.
- F. Exclusion for exceeding the maximum permitted lateness may be applied at any control or the end of the rally. It may also be applied by sweep.
- G. The Maximum Permitted Earliness (MPE) for the entire event will be ten minutes.
- H. Exceeding ten minutes earliness on transits will cause the competitor to be excluded from the event.

## XXV. Sweep:

- A. There will be two sweep vehicles. One will be stationed at stage start. The second will be stationed at a stage midpoint. In the case of an incident, a sweep vehicle may be dispatched to clear the road. Disabled vehicles will be dealt with as necessary, when time allows.
- B. The Safety Sweep team follows closely behind the final competing vehicle. Their primary purpose is to discover what assistance is required by disabled vehicles/teams and to pass this information to Net Control and Sweep. They are unable to take passengers.
- C. Maximum Permitted Lateness (MPL)
  - 1. Will be defined in a competitor bulletin soon
- D. Closely following Safety Sweep will be Medical and 4x4 Sweep teams who will provide medical support and/or attempt to move your disabled vehicle. If a stage will be run again, you will only be moved if you are blocking the course. When the stage is closed after its final use, Sweep will attempt to move your car to the end of the stage where your service crew or a wrecker can be dispatched to meet you.
- E. Competitors can accept assistance from sweep and remain in the rally. The decision to help or not is entirely up to sweep. Competitor must not have reached MPL. Competitor must continue down the stage in front of all Sweep and Medical vehicles. All safety equipment must be properly worn including Helmets, Hans and belts before the car continues.
- F. Emergency Instructions for rally teams are summarized on a sheet in the back of the Route Book for your convenience.

## XXVI. Event Communications

- A. It is anticipated that event radio nets will be operating on the following frequencies.
  - 1. N3FE repeater: 146.910 mhz., neg offset of 0.60 mhz, pl tone 71.9
  - 2. NR3K repeater: 147.060 mhz., pos offset of 0.60 mkz., pl tone 127.3 or
  - 3. NR3K repeater: 145.270 MHz, neg offset of 0.60 MHz, pl tone of 127.3 Hz
  - 4. 147.55 simplex
- B. Teams are not allowed to transmit on these frequencies except in case of emergency for emergency traffic.

## XXVII. Food and beverages:

- A. Food: Teams should bring their own food for the day.
- B. Beverages: Teams should bring their own beverages for the day. There is no consumption of alcoholic beverages before or during the RallySprint.
- C. There will be a food service available for purchase at the spectator area during the event.
- D. Buffet dinner will be provided at the Fairgrounds after the competition has ended. Each team is allowed 4 people at the dinner. Additional dinner tickets are available at the dinner.

## XXVIII. Spectating: All persons attending the RallySprint will follow instructions of the

marshals. Team members and crew members have no special viewing privileges and must spectate only in approved areas.

**XXIX. Lodging:**

- A. See the <http://www.wellsboropa.com/home-top> web pages for information about dining, Lodging and visiting Wellsboro PA.
- B. The Wellsboro Chamber of Commerce is a large sponsor and advocate for Rally in the area. Please patronize their members and thank them for their support.

**XXX. Results:**

- A. Informational scores will be posted at the net control building during the event Saturday.
- B. Provisional results will be posted at the After-Rally Party in the main building at the Tioga County Fairgrounds ASAP after the Rally is complete.
- C. Teams will have 30 minutes to review the provisional results and file inquiries with the Event Steward or Event Chair.
- D. Final results will be posted to the WMWR web page.

**XXXI. Awards:**

- A. Awards will be presented at the After-event party at the Fairgrounds after the 30 minute review period has ended and any inquiries resolved.
- B. At a minimum, trophies will be awarded to the first-place car in each class as well as the First Overall four-wheel drive vehicle and the First Overall two-wheel drive vehicle.
- C. Trophies will not be mailed to those competitors who cannot pick them up at the awards ceremony. If you cannot stay for the awards banquet, please arrange to have your trophy picked up.

**XXXII. Final Checks and Protests:**

- A. All finishing vehicles are required to remain in the Impound area until released by the Event Steward or designee, or referred for additional inspection as directed.
- B. Inquiry forms are in the Route Book, and will be available at the scoring location. All inquiries will be investigated, and their disposition posted.
- C. Claim forms are available from the Stewards.